

# CT Reconstruction with Good-Orientation and Layer Separation for Multilayer Objects

Tong LIU<sup>1</sup>, Brian Stephan WONG<sup>2</sup>, Tai Chong CHAI<sup>3</sup>, and Andrew. A. MALCOLM<sup>1</sup>

<sup>1</sup> Singapore Institute of Manufacturing Technology

71 Nanyang Drive, Singapore 638075

Phone: +65 67938326; Fax: +65 67916377; E-mail: [tliu@simtech.a-star.edu.sg](mailto:tliu@simtech.a-star.edu.sg)

<sup>2</sup> School of MAE, Nanyang Technological Univ., Singapore; E-mail:

<sup>3</sup> Institute of Microelectronics, Singapore; E-mail:

## Abstract

Nowadays, multilayer designs such as temperature co-fired ceramic (LTCC) and stacked IC packaging are increasingly popular in electronics and semiconductor industries. For these multilayer structures, X-ray CT is thought as one of the essential tools for inspecting their internal defects. A common requirement for X-ray CT inspection of multilayer objects is to visualize the reconstructed CT results in separated layers so that defect analysis can be conducted layer-wise and conveniently corresponded to manufacturing process. One characteristic of multilayer objects is that the layers are usually thin and have a large area-to-thickness aspect ratio. This property sometimes may lead to failure in inspecting thin defects. For example, thin and large delamination-like defects in a multilayer packaging are in many cases invisible to X-ray 2D imaging. If the user has no prior knowledge about their existence, they are also quit easy to be missed with CT images if the reconstructed object has a tilted orientation. In this paper, we demonstrate that a good-oriented CT reconstruction for planar object can make layer separation much more simple and effective. Through the study of a 5 – layer packaging sample, we also show that more detailed information of the delamination-like defects can be observed.

**Subject terms:** Computed tomography, multilayer object, layer separation, NDT, CT.

## 1. Background

Traditional micro-CT usually reconstructs an object without considering its actual scanning orientation with respect to the detector plane and the rotary unit. As a result, the object is usually reconstructed with a tilted orientation (Fig. 1a). Although this has no any impact on the reconstruction quality, it indeed causes some trouble in the processes of separating layers in a reconstructed multilayer component such as stack IC chip or low temperature co-fired ceramic (LTCC) device<sup>[1]</sup>.

Several powerful software packages are available in the market for CT visualization, such as VGStudio Max<sup>2</sup> and I-view<sup>3</sup>. With these softwares, the way to separate a multilayer component with a tilted reconstruction orientation is to cut it with a clip-plane defined along the normal of the layer plane. This process is generally very time-consuming even for experienced users. It is also quite subjective because it relies purely on the personal judgment of the user for the definition of the clip-plane. An imperfect definition would lead to an unacceptable separation of layers (Fig. 1b).

The tilted orientation of a reconstructed planar object comes from two sources. Firstly, almost all CT software performs the reconstruction with a default scanning start angle, for example zero. However, in reality, an object may be scanned with any initial orientation, as illustrated in Fig.2 (a). A difference between the default start angle and the actual start angle would result in the titling of the object CT slice with respect to the reconstruction matrix. Secondly, when mounting a planar object, its primary plane may form a small angle with the rotation axis (Fig.2(b)). This situation would lead the reconstructed object to be misaligned in the third dimension in a volume reconstruction process.

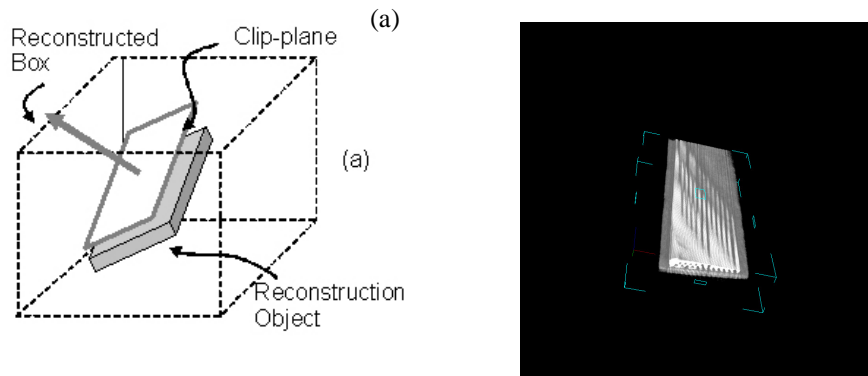

Fig. 1 (a) An object is reconstructed with a tilted orientation with respect to the dimensions of reconstruction box; (b) A poor cutting with a inaccurate clip-plane definition.

In principle, this problem can be solved physically by carefully positioning the planar object on the rotator before the scanning. However, in many cases this has proven to be impractical or at least very difficult to achieve because of the lack of accurate referencing and the variation of sample shape and size.

Recently we have developed an automated algorithm that enables users to reconstruct planar objects with a wanted orientation<sup>[4,5]</sup>. That is, to make the object's primary plane aligned with one plane of the reconstruction volume so that layer separation can be carried easily along one dimension of the reconstruction volume. This technology first uses one sinogram of the object to automatically determine the actual start angle of a scan, with which the CT reconstruction is conducted to achieve an aligned orientation between the object slice and the reconstruction matrix. After all slices reconstructed, the height position of the object cross-section on each slice is calculated and an image shifting operation to all slices is applied to make the object is also well aligned in the third dimension of the reconstruction volume. As a result, the primary plane of the reconstructed object will be parallel to one of the planes of the reconstruction volume. With such an orientation, displaying and extracting layers becomes a trivial operation.

In this paper, through investigating the defects inside a five-layer packaging sample, we will demonstrate the benefit of the new technology over the traditional method. To support our statements and conclusions drawn from the study, some C-mode Scanning Acoustic Microscopy (CSAM) images are also provided as reference<sup>[6]</sup>.

## 2. Methodology

The sample was investigated with C-mode Scanning Acoustic Microscopy (CSAM) first and then with a micro-focus X-ray inspection machine (XIM). The comparison of the CSAM image and 2D X-ray image showed some inconsistent results, which made it hard to draw a conclusion. Then an X-ray CT scan was used to create the 3D model of the sample. First, we reconstructed the object by using commercial software with a default scanning

start angle. However, due to the existence of a small angle between the primary plane of the sample and the rotation axis and the difference between the actual scanning start angle and the default one, we obtained a reconstructed object with a titled orientation. By carefully defining a clip-plane we were able to extract the images of the two interface layers that are to an extent matching the images of the CSAM images, however, without any prior knowledge about the defects, we were unable to judge how good is the layer images obtained and whether we could observe more details from the reconstructed results. Therefore, we re-did the volume reconstruction with the actual scanning start angle and then perform an axial tilting correction to the reconstructed data. This process gave us a reconstructed object with an expected orientation. With this good orientation, we were able to easily extract the individual layers with much more details through an automated layer separation approach.

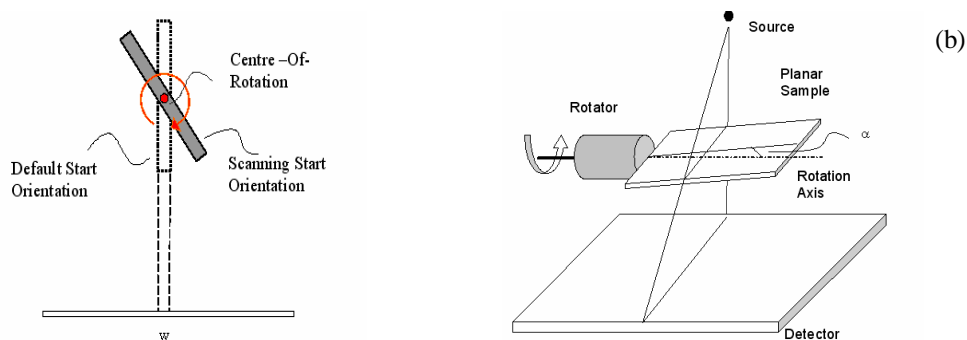

Fig.2. The scanning start orientation of a planar object. (a) An arbitrary start angle; (b) An angle exists between the primary plane of the object and the rotation axis.

### 3. Experiment and Discussion

#### 3.1 Sample Description

The sample to be investigated in this paper is a five-layer packaging sample as illustrated in Fig.3. The three silicon layers are assembled with adhesive materials that form the two interface layers. It has a size of 10mm×10mm×2mm. Each silicon layer is 600μm and each interface layer is 100μm. This sample was specially prepared for evaluating the assembly processing. The inspection objective was to check what would have happened on the two adhesive layers. Interesting defects include voids and delamination-like gaps.

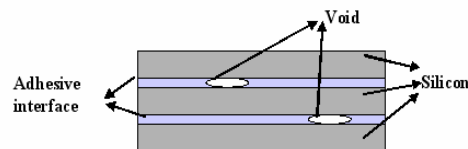

Fig. 3. The five-layer package sample

#### 3.2 CSAM and X-ray 2D Images

The sample was investigated with C-mode Scanning Acoustic Microscopy (CSAM) first and then with a micro-focus X-ray inspection machine (XIM). For CSAM inspection, one of the two interfaces was scanned first (Fig.4 (a), labelled as the first interface). The sample was then inverted and the second interface was scanned (Fig. 4(b)). For comparison purpose, one X-ray 2D image was also captured with same position as the CSAM images (Fig. 4(c)).

The CSAM system used in the experiment was a Sonoscan D300. The sample was scanned at a frequency of 230 MHz, with a scanning area of 20mm-by-20mm and a resolution of 256-by-240 pixels.

The X-ray inspection machine was a Comet/Feinfocus Fox 160.25. It has an open tube with spot size as small as 700nm, and a 200mm x 197mm direct digital detector (Varian Paxscan 2520). The detector has 1408-by-1888 pixels and each pixel is 127  $\mu\text{m}$  in size. The detector can work in either full frame or binning mode in order to generate images of different size to optimise image acquisition time and data storage.

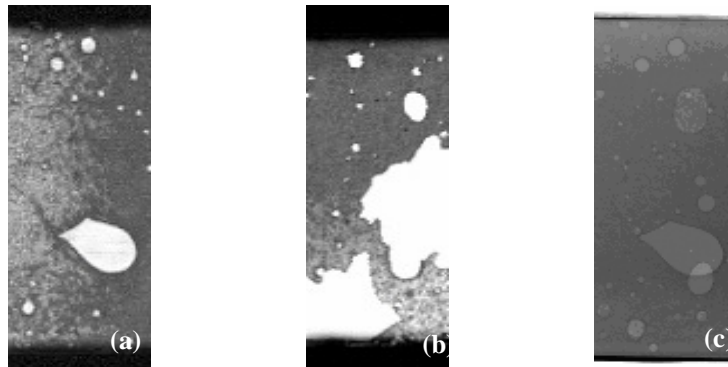

Fig. 4 CSAM and X-ray Images. (a) CSAM image of the first interface; (b) CSAM image of the second interface; (c) X-ray 2D image.

In principle, voids, cracks, and delamination, if detectable, will show as white areas in both the CSAM and X-ray 2D images. For CSAM this is because acoustic waves cannot pass through an air gap, and for X-ray, because these kinds of defects lead to less absorption of the X-ray beam. For X-ray inspection, it generally makes no difference to have the sample facing up or down. For CSAM, by setting an appropriate time gate, the two interfaces can be scanned and inspected separately.

It is easy to become confused when comparing the X-ray images and the CSAM images. While most of the defects on the CSAM image of the first interface can also be found on the X-ray image, the CSAM image of the second interface shows little similarity to the X-ray image. Obviously, there were some thin and large delamination-like defects existing on this interface, however, because they are too thin, they are not visible on the X-ray 2D image.

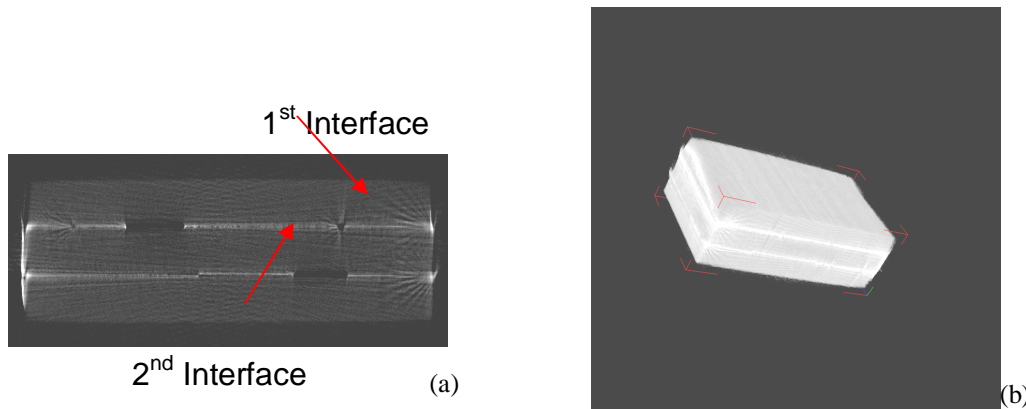

Fig. 5. One CT slice (a) and the 3D model of the reconstructed part of the object with the new method (b).

### 3.3 CT reconstruction with the actual start angle and axial tilting correction

As 2D X-ray inspection was unable to detect this kind of delamination-like defects, we then resorted to the CT inspection. The sample was scanned with a source-to-image distance of 680mm and a source-to-object distance of 61mm. The source was set at an accelerating voltage of 100kV and a tube current of 37 $\mu\text{A}$  using a

tungsten target. The object was rotated through  $360^\circ$  to complete the scan with one projection image being taken at each degree.

One sinogram was then created, from which the actual scanning start angle can be determined <sup>[4]</sup>. Then the cone-beam volume reconstruction algorithm was used to reconstruct the object with the actual scanning start angle obtained. One slice image was shown in Fig. 5a, in which the object dimensions were well aligned with the dimensions of the reconstruction matrix. Totally 500 axial slices were reconstructed in this study for the area shown in Fig. 4. Then, the tilting angle of the object's primary plane with respect to the rotation axis was determined from the projection that has the narrowest shadow on detector after performing a fan-beam to parallel-beam conversion. This tilting angle was then used to perform a image shifting operation to all slices to make the reconstructed object also aligned with the reconstruction box in the third dimension, as shown in Fig. 5b <sup>[5]</sup>. As a consequence, the primary plane of the reconstructed object was parallel to one plane of the reconstruction box and therefore. If a layer-separation operation was necessary, it could be accomplished by cutting the object digitally along one dimension of the reconstruction box.

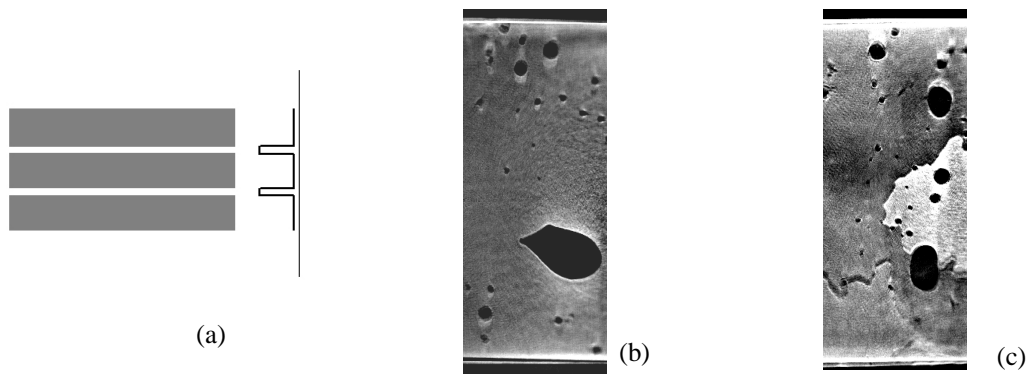

Fig.6 Automated layer separation. (a) The concept; (b) the first interface; (c) the second interface

### 3.4 Automated layer separation

With a good oriented reconstruction, it is also able to perform an automated layer separation. As illustrated in Fig. 6, to obtain the individual layers in a sample, we performed a sum operation over each row and generated a integrated intensity distribution over the row number as shown in Fig. 6a. With the positions of the two layers determined, the images of the two individual layers were obtained automatically (Figs. 6b and 6c).

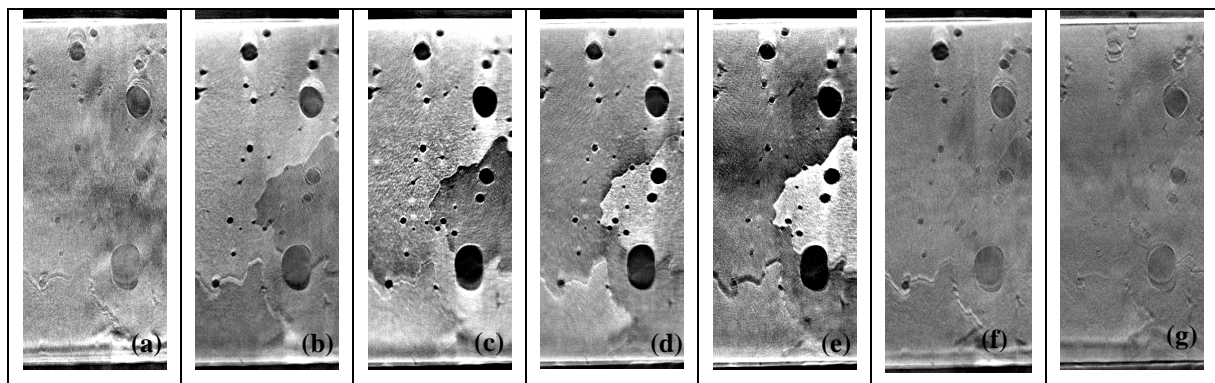

Fig.7. The cross-sectional CT images of the second interface with the new method.

Another advantage of the reconstruction with a good orientation lies on the availability to easily show the variation within the interface layer in this study. From the distribution illustrated in Fig. 6a, one could have an

estimate about the width of the interfaces that might be several pixels, depending on the reconstruction resolution in the thickness dimension. Therefore, to display the slice with a one-pixel increment, we were able to view the variation of the defects in the interface, as shown in the Fig. 7.

This detailed information in Fig. 7 showed rather different scenario to that shown in the CSAM image. Fig.7(a)-(g) showed the cross-sectional images of the second interface from bottom to top. One could immediately notice that Fig.7(c) was very similar to the defects shown in Fig. 4(b). However, for other positions, the defect was quite different. In fact, the several defects recognized in Fig.4(b) were actually located at different heights within the second interface. Some of them were located between the second silicon layer and the adhesive material layer; some of them were between the adhesive layer and the third silicon layer. For example, the delamination-like areas shown in Fig. 7(c) as lower gray level became adhesive material areas in Fig. 7(e). What this means to the assembling process might be a question we need to answer in the future.

#### 4. Conclusion

In this paper, we demonstrate that delamination-like defects can be more effectively inspected and visualised with an automated good-oriented reconstruction for multilayer planar objects. Due to the small thickness of this kind of defects, 2D X-ray inspection is usually unable to detect them reliably. They are also generally not guaranteed to be detected with traditional CT reconstruction and visualisation approaches due to the tilted orientation of the reconstructed object and the subjective definition of a clip-plane.

Our new method allows a good-oriented reconstruction of the planar object and an automatic layer separation of internal layers. Compared to traditional approach, the present method is automated effective and subjective. In many cases, it also allows the user to extract more feature details within a thin layer. This characteristic is proven to be useful in analysing the forming mechanism of the voids or delamination in packaging process.

#### References

- [1] M. Pacheco, Z. Wang, L. Skoglund, Y. Liu, A. Madina, A. Raman, R. Dias, D. Goyal and S. Ramanathan, "Advanced fault isolation and failure analysis techniques for future package technologies", *Intel Technology Journal*: vol. 9(4), 2005.
- [2] User's Manual, VGStudio Max 1.2, first printing, Mar , 2004.
- [3] Users Manual, i-View Workstation Version 1.0, 2003.
- [4] T. Liu, 'Fast automated center-of-rotation determination in computed tomography technology', SIMTech Invention Disclosure, ID-P-07-013, 2007.
- [5] T. Liu, 'CT reconstruction for planar object and automated layer separation', SIMTech Invention Disclosure, ID-P-07-017, 2007.
- [6] T. Adams, "Acoustic Micro Imaging of Stacked Die", *Semiconductor International*, <http://www.semiconductor.net/article/CA604506.html>, 2005.